

Type: MXPRC/S

Phase Failure, Phase Sequence, Under and Over Voltage plus Time Delay

- ☐ 17.5mm DIN rail housing
- ☐ True R.M.S.
- ☐ Microprocessor based (self checking)
- ☐ Monitors own supply and detects if one or more phases exceed the set Under or Over Voltage trip levels
- ☐ Measures phase to phase voltages
- ☐ Detects incorrect phase sequence and phase loss
- ☐ Adjustments for under and over voltage trip level
- ☐ Adjustment for time delay (from under or over voltage condition)
- ☐ 1 x SPDT relay output 8A
- ☐ Intelligent LED indication for supply and relay status



Dims:
to DIN 43880
W. 17.5mm

Terminal Protection to IP20

FUNCTION DIAGRAM

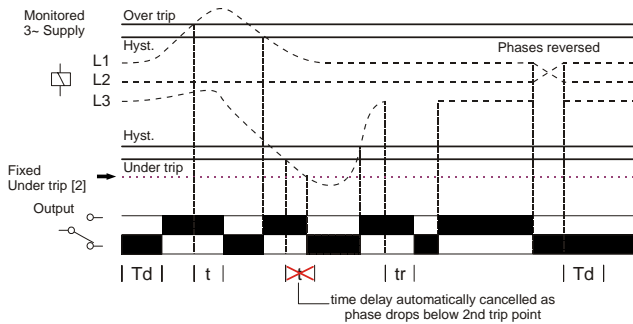

INSTALLATION AND SETTING



Installation work must be carried out by qualified personnel.

- BEFORE INSTALLATION, ISOLATE THE SUPPLY.
- Connect the unit as required. The Connection Diagram below shows a typical installation, whereby the supply to a load is being monitored by the Phase monitoring relay. If a fault should occur (i.e. fuse blowing), the relay will de-energise and assuming control of the external Contactor, de-energise the Contactor as well.

Applying power.

- Set the "Over %" adjustment to maximum and the "Under %" adjustment to minimum. Set the "Delay (t)" to minimum.
- Apply power and the green "Power supply" and red "Relay" LED's will illuminate, the relay will energise and contacts 15 and 18 will close. Refer to the troubleshooting table if the unit fails to operate correctly.

Setting the unit.

- Set the "Over %" and the "Under %" adjustments to give the required monitoring range.
- If large supply variations are anticipated, the adjustments should be set further from the nominal voltage.
- Set the "Delay (t)" adjustment as required. (Note that the delay is only effective should the supply increase above or drop below the set trip levels. However, if during an under voltage condition the supply drops below the 2nd under voltage trip level, any set time delay is automatically cancelled and the relay de-energises).

Note: If the supply voltage increases above the maximum "Over %" trip setting by approx. 5% or more, the relay will de-energise immediately.

Troubleshooting.

The table below shows the status of the unit during a fault condition.

Supply fault	Green LED	Red LED	Relay
Phase missing	On	Off	De-energised
Phases reversed (no delay)	Flashing	Off	De-energised
Under or Over Voltage condition (during timing)	On	Flashing	Energised for set delay (t)
Under or Over Voltage condition (after timing)	On	Off	De-energised
Phase below 70% of Un (fixed under trip level [2])	On	Off	De-energised

CONNECTION DIAGRAM

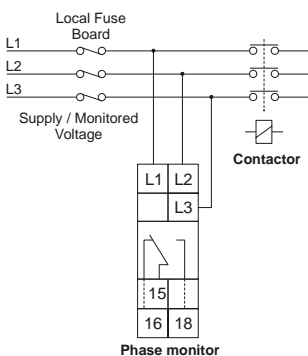

SETTINGS

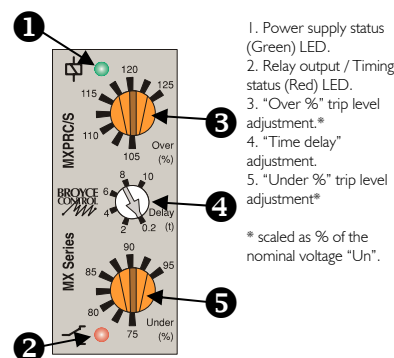

TECHNICAL SPECIFICATION

Supply / monitoring voltage Un* (L1, L2, L3): 110, 208, 220, 380¹, 400¹, 415V¹ AC
 Frequency range: 48 - 63Hz
 Supply variation: 70 - 130% of Un
 Isolation: Over voltage cat. III
 Rated impulse withstand voltage: 4kV¹ (1.2 / 50μs) IEC 60664
 Power consumption: 8VA max.

*Please state Supply / monitoring voltage when ordering

Trip levels:

Under [2]:	70% of Un (fixed) ±2%		
Under:	75 - 95% of Un		
Over:	105 - 125% of Un		

Measuring ranges:

	Under [2]	Under	Over
110V:	77V	83 - 105V	116 - 138V
208V:	146V	156 - 197V	218 - 260V
220V:	154V	165 - 209V	231 - 275V
380V:	266V	285 - 361V	399 - 475V
400V:	280V	300 - 380V	420 - 500V
415V:	290V	311 - 394V	436 - 519V

Hysteresis: ≈ 2% of trip level (factory set)
 Setting accuracy: ± 3%
 Repeat accuracy: ± 0.5% @ constant conditions
 Immunity from micro power cuts: < 50mS
 Response time: ≈ 50mS
 Time delay (t): 0.2 - 10 sec (± 5%)
 Note: actual delay (t) = adjustable delay + response time
 Delay from phase loss (tr): ≈ 150mS (worst case = tr x 2)
 Power on delay (Td): ≈ 1sec. (worst case = Td x 2)

Ambient temp: -20 to +60°C
 Relative humidity: +95%
 Output (15, 16, 18): SPDT relay
 Output rating: AC1 250V 8A (2000VA)
 AC15 250V 5A (no), 3A (nc)
 DC1 25V 8A (200W)
 Electrical life: ≥ 150,000 ops at rated load
 Dielectric voltage: 2kV AC (rms) IEC 60947-1
 Rated impulse withstand voltage: 4kV (1.2 / 50μs) IEC 60664
 Housing: Orange flame retardant UL94 V0
 Weight: ≈ 70g
 Mounting option: On to 35mm symmetric DIN rail to BS5584:1978 (EN50 002, DIN 46277-3) Or direct surface mounting via 2 x M3.5 or 4BA screws using the black clips provided on the rear of the unit.
 Terminal conductor size: ≤ 2 x 2.5mm² solid or stranded
 Approvals: Conforms to IEC, CE and RoHS Compliant.
 EMC: Immunity: EN/IEC 61000-6-2 (EN/IEC 61000-4-3 15V/m 80MHz - 2.7GHz)
 Emissions: EN/IEC 61000-6-4

Options:

1. The unit is also available with a double-pole relay output. Refer to separate data sheet for Mxprc/s/2.

MOUNTING DETAILS

