

Type: MXPRT

Phase Failure, Phase Sequence and Under Voltage plus Time Delay

- ☐ 17.5mm DIN rail housing
- ☐ True R.M.S.
- ☐ Microprocessor based (self checking)
- ☐ Monitors own supply and detects an Under voltage condition on one or more phases
- ☐ Measures phase to phase voltages
- ☐ Detects incorrect phase sequence and phase loss
- ☐ Adjustment for under voltage trip level
- ☐ Adjustment for time delay (from an under voltage condition)
- ☐ 1 x SPDT relay output 8A
- ☐ Intelligent LED indication for supply and relay status



Dims:
to DIN 43880
W. 17.5mm

Terminal Protection to IP20

FUNCTION DIAGRAM

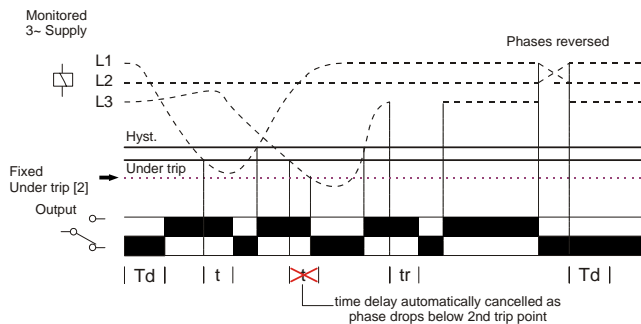

INSTALLATION AND SETTING



Installation work must be carried out by qualified personnel.

- BEFORE INSTALLATION, ISOLATE THE SUPPLY.
- Connect the unit as required. The Connection Diagram below shows a typical installation, whereby the supply to a load is being monitored by the Phase monitoring relay. If a fault should occur (i.e. fuse blowing), the relay will de-energise and assuming control of the external Contactor, de-energise the Contactor as well.

Applying power.

- Set the adjustments "<U"&sup>1</sup> and the "Delay (t)"&sup>2</sup> to minimum.
- Apply power and the green "Power supply"&sup>1</sup> and red "Relay"&sup>2</sup> LED's will illuminate, the relay will energise and contacts 15 and 18 will close. Refer to troubleshooting table if the unit fails to operate correctly.

Setting the unit.

- Accurate setting can be achieved by adjusting the trip level "<U"&sup>1</sup> until the unit trips (relay de-energises) then by decreasing the trip level "<U"&sup>1</sup> setting until the relay re-energises. By close setting of the trip level, the unit will also detect a phase loss even with a large percentage of re-generative voltage.
- In order to set the unit as previously described but without causing disruption to the equipment being controlled/monitored, set the "Delay (t)"&sup>2</sup> to maximum. It will now be possible to establish the trip point when the red "Relay"&sup>2</sup> LED starts to flash. Decrease the trip level setting to stop the LED flashing. (Note: If the time delay is allowed to expire, the output relay will de-energise)
- If large supply variations are anticipated, the trip level should be set further from the nominal voltage.
- Set the "Delay (t)"&sup>2</sup> as required. (Note that the delay is only effective should the supply drop below the set trip level. However, if during an under voltage condition the supply drops below the 2nd under voltage trip level, any set time delay is automatically cancelled and the relay de-energises).
Note: If the supply voltage increases above the maximum "<U"&sup>1</sup> trip setting by approx. 10% or more, the relay will de-energise immediately.

Troubleshooting.

The table below shows the status of the unit during a fault condition.

Supply fault	Green LED	Red LED	Relay
Phase missing	On	Off	De-energised
Phases reversed (no delay)	Flashing	Off	De-energised
Under Voltage condition (during timing)	On	Flashing	Energised for set delay (t)
Under Voltage condition (after timing)	On	Off	De-energised
Phase below 70% of Un (fixed under trip level [2])	On	Off	De-energised

CONNECTION DIAGRAM

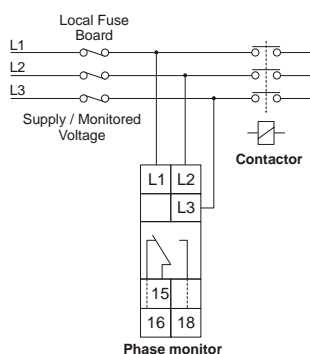

SETTINGS

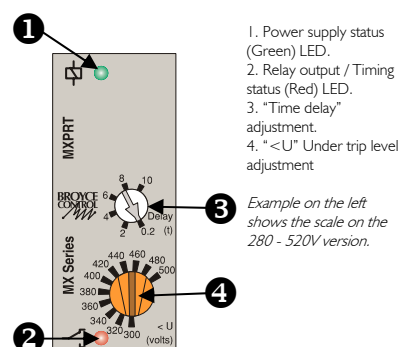

TECHNICAL SPECIFICATION

Supply / monitoring voltage U* (L1, L2, L3):	77 - 143V AC 161 - 300V AC 280 - 520V AC ¹ 48 - 63Hz	*Please state Supply / monitoring voltage when ordering
Frequency range:	Over voltage cat. III	
Isolation:	Over voltage cat. III	
Rated impulse withstand voltage:	4kV ¹ (1.2 / 50μs) IEC 60664	
Power consumption:	8VA max.	
Trip levels:		
Voltage range:	Under [2] fixed ±2%: 77V 161V 280V	Under (adjustable): 83 - 138V 173 - 288V 300 - 500V
Hysteresis:	≈ 2% of trip level (factory set)	
Setting accuracy:	± 3%	
Repeat accuracy:	± 0.5% @ constant conditions	
Immunity from micro power cuts:	< 50 mS	
Response time:	≈ 50 mS	
Time delay (t):	0.2 - 10 sec (± 5%) Note: actual delay (t) = adjustable delay + response time	
Delay from phase loss (tr):	≈ 150 mS (worst case = tr x 2)	
Power on delay (Td):	≈ 1 sec. (worst case = Td x 2)	
Ambient temp:	-20 to +60°C	
Relative humidity:	+95%	
Output (15, 16, 18):	SPDT relay	
Output rating:	AC1 250V 8A (2000VA) AC15 250V 5A (no), 3A (nc) DC1 25V 8A (200W)	
Electrical life:	≥ 150,000 ops at rated load	
Dielectric voltage:	2kV AC (rms) IEC 60947-1	
Rated impulse withstand voltage:	4kV (1.2 / 50μs) IEC 60664	
Housing:	Orange flame retardant UL94 VO	
Weight:	≈ 70g	
Mounting option:	On to 35mm symmetric DIN rail to BS5584:1978 (EN50 002, DIN 46277-3) Or direct surface mounting via 2 x M3.5 or 4BA screws using the black clips provided on the rear of the unit.	
Terminal conductor size:	≤ 2 x 2.5mm ² solid or stranded	
Approvals:	Conforms to IEC, CE and and RoHS Compliant. EMC: Immunity: EN/IEC 61000-6-2 (EN/IEC 61000-4-3 15V/m 80MHz - 2.7GHz) Emissions: EN/IEC 61000-6-4	
Options:	1. The unit is also available with a double-pole relay output. Refer to separate data sheet for Mxprrt/2.	

MOUNTING DETAILS

